

ALUMINUM TRUCK BED RACK INSTALLATION MANUAL

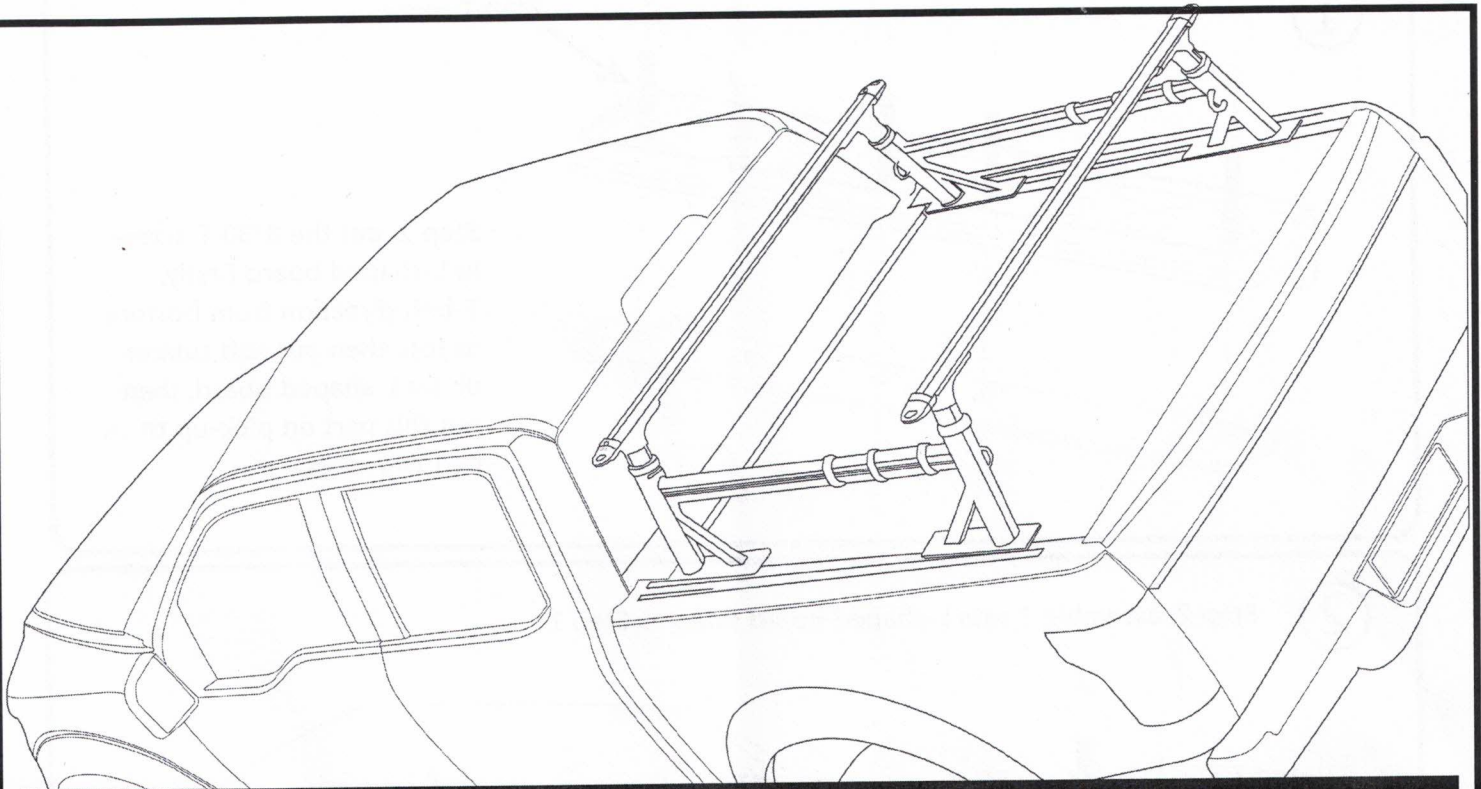

Contents · Contenu · Contenido

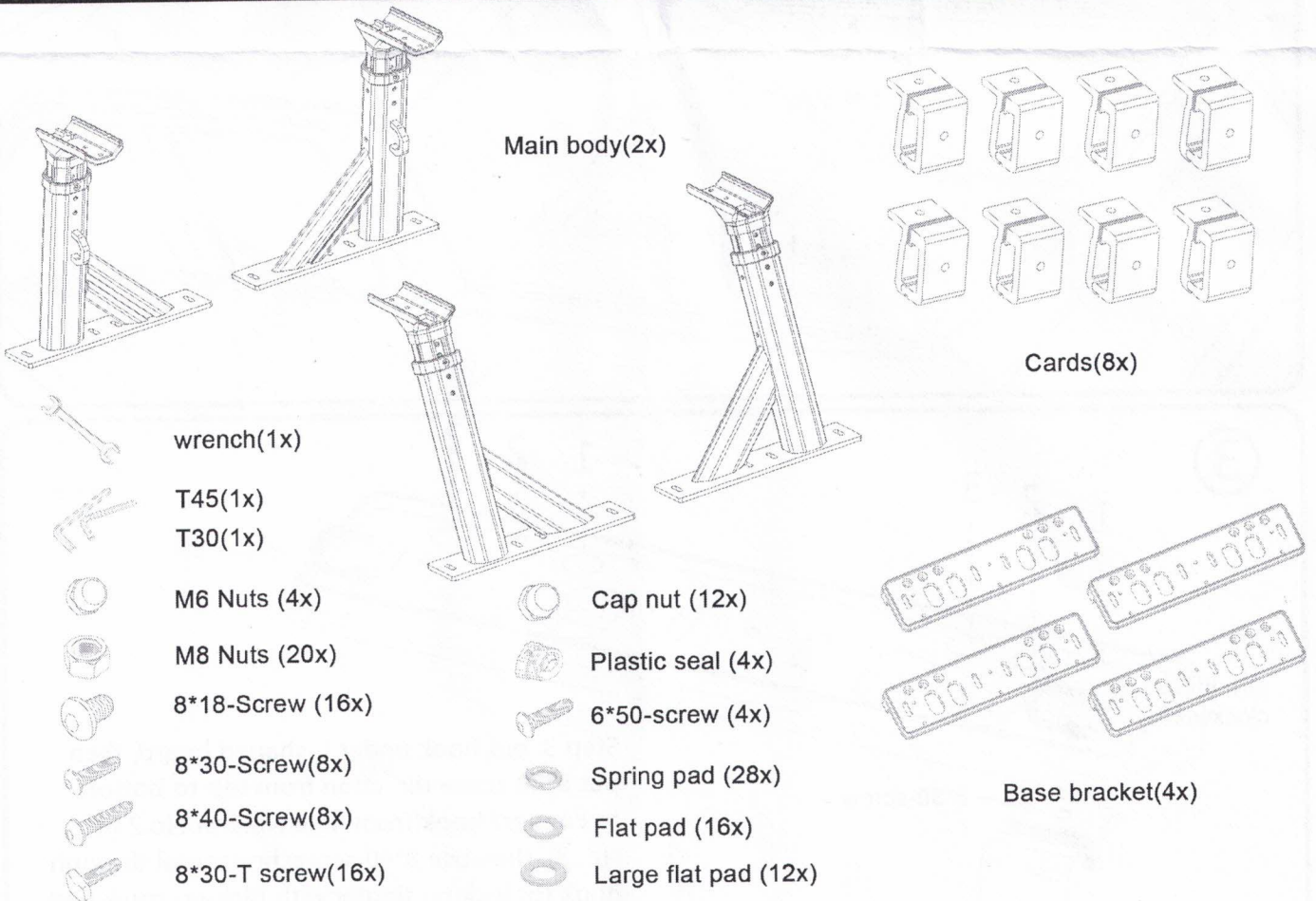

ROLL BAR WITHOUT ROLL COVER

①

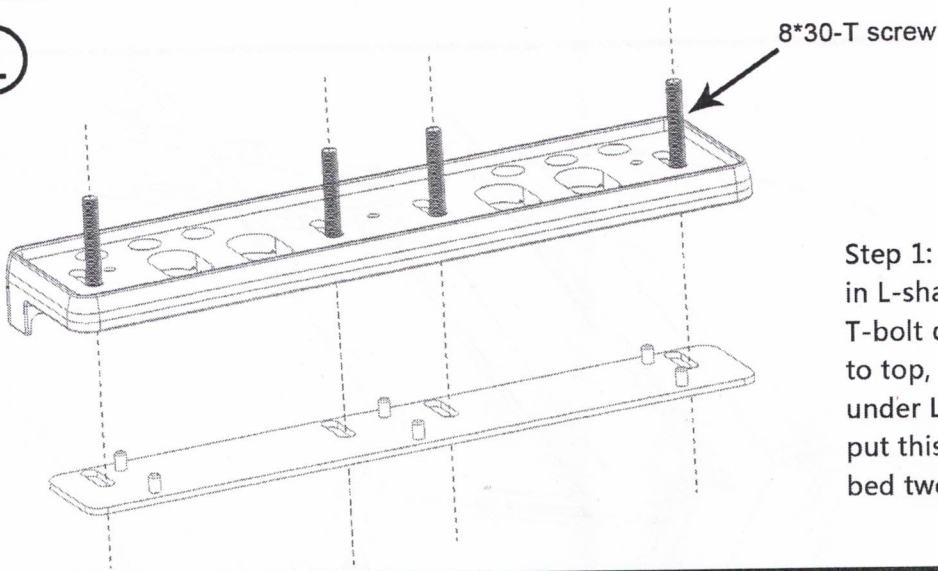

Step 1: put the 8*30 T-screw in L-shaped board firstly, T-bolt direction from bottom to top, then put soft rubber under L-shaped board, then put this part on pick-up truck bed two sides

②

Step 2: assemble 4 sets L-shaped board same as Step 1

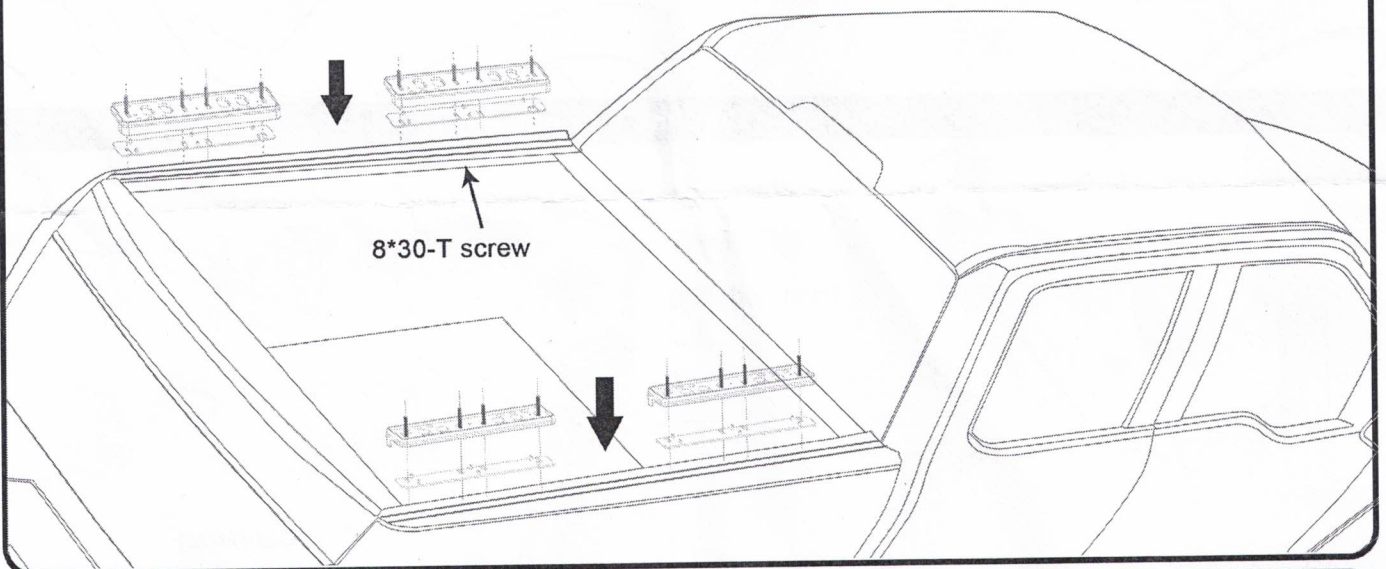

③

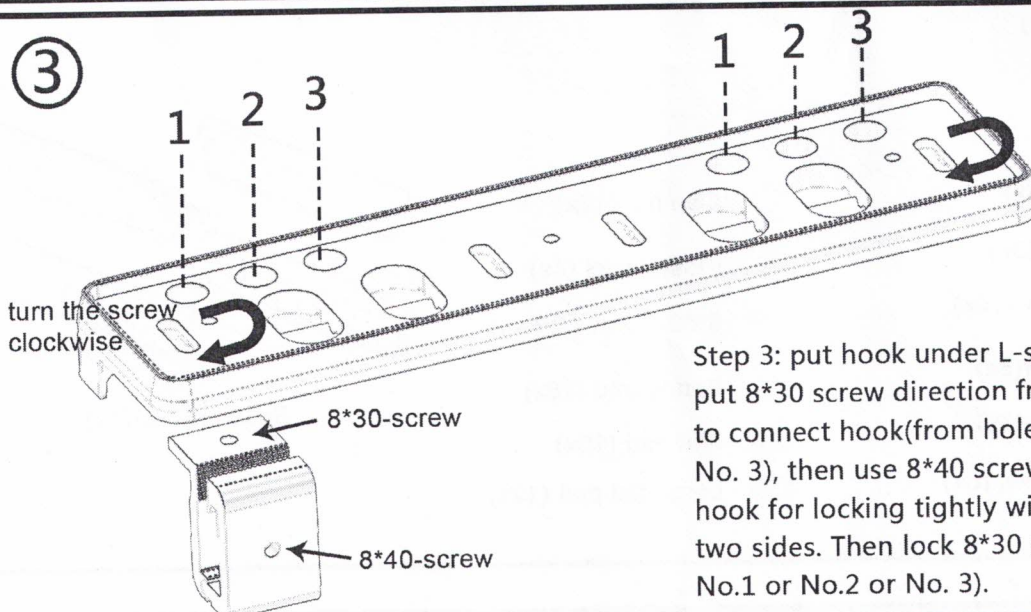

Step 3: put hook under L-shaped board, then put 8*30 screw direction from top to bottom to connect hook(from hole No.1 or No.2 or No. 3), then use 8*40 screw horizontal through hook for locking tightly with pick-up truck bed two sides. Then lock 8*30 screw tightly(from hole No.1 or No.2 or No. 3).

④

Step 4: put 4 legs on 4 L-shaped board, then put pad and nut to lock

Measure the appropriate size, the two sides need to be symmetrical and consistent.

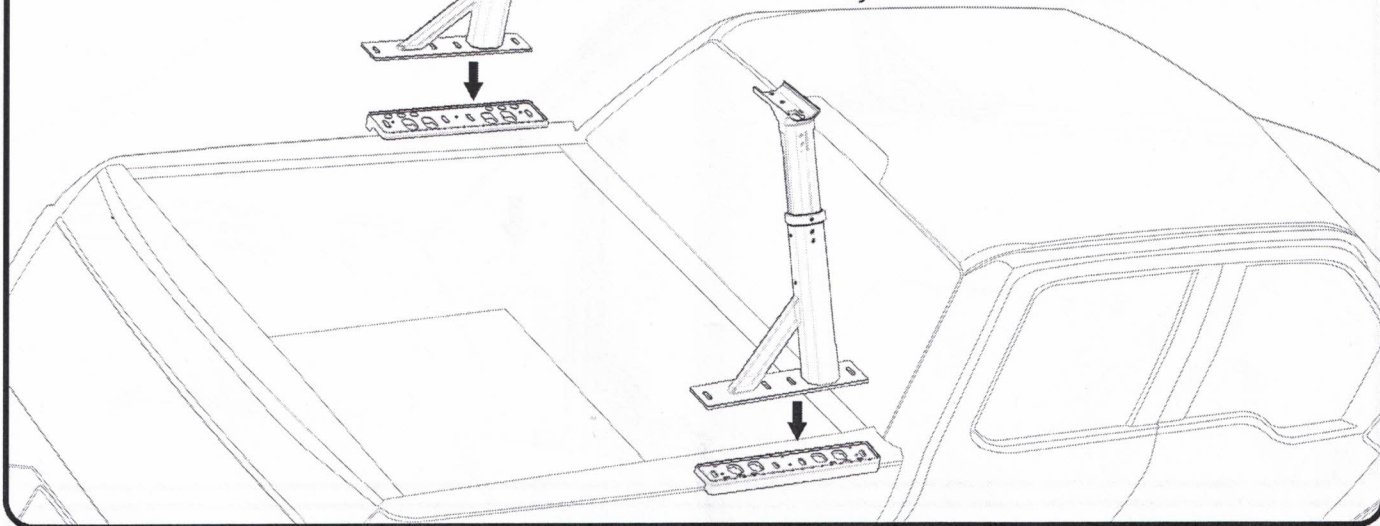

⑤

Step 5: Measure the height that needs to be adjusted and adjust to the appropriate height.

Loosen the screw on the post, adjust to the desired height, and observe the position of the scale value.

Repeat the previous step, adjust the 4 posts to the same height, and tighten all the screws on the 4 posts with a wrench.

Lock after adjusting properly.

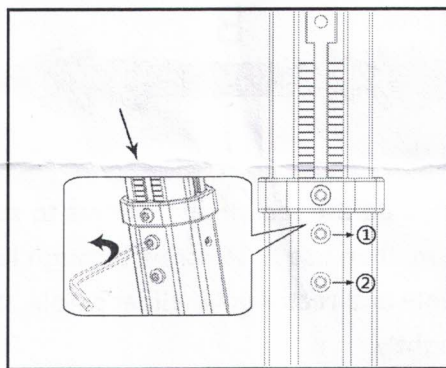
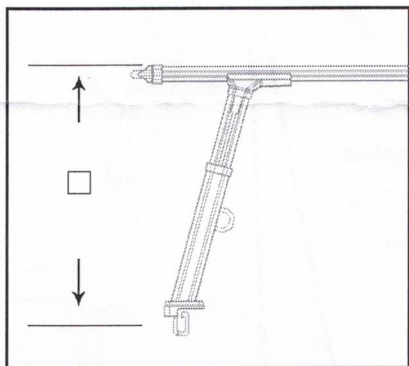

Loosen ①② screws properly, do not loosen all screws.

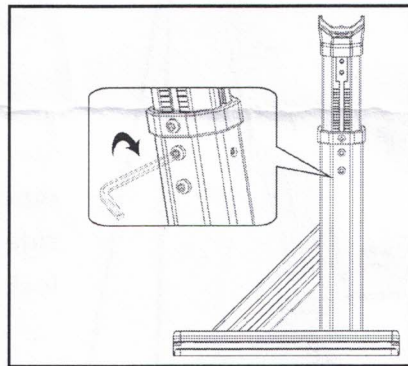

⑥

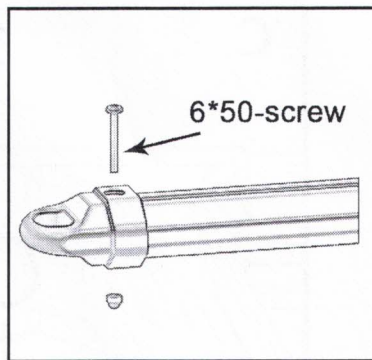
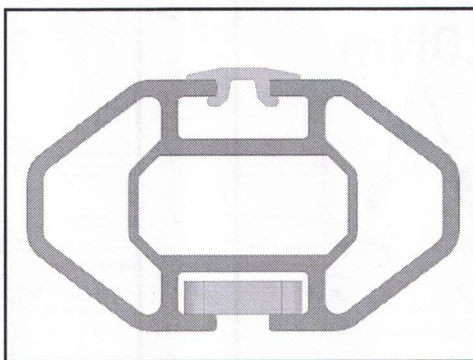
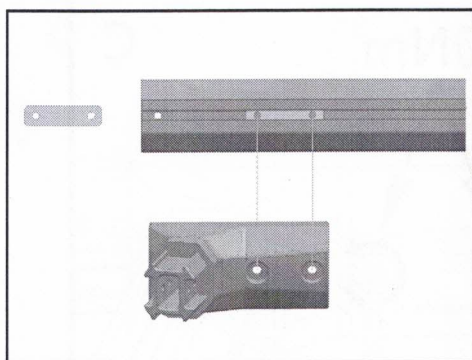

Step 6: put the rectangular slider slides into the bottom groove of roof bar (1 bar puts 2 rectangular sliders) and then put side caps on bars, use 6*50-screw to fix

7

Step 7: put roof bars on 4 legs

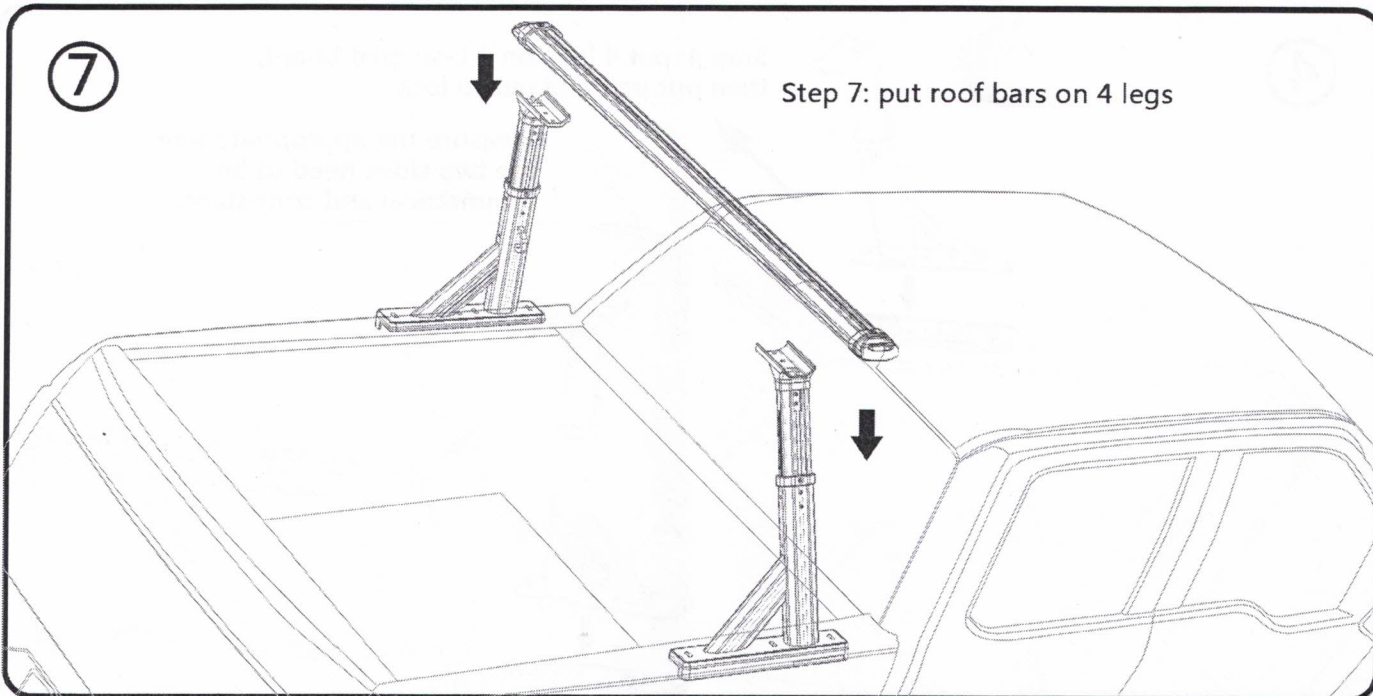

8

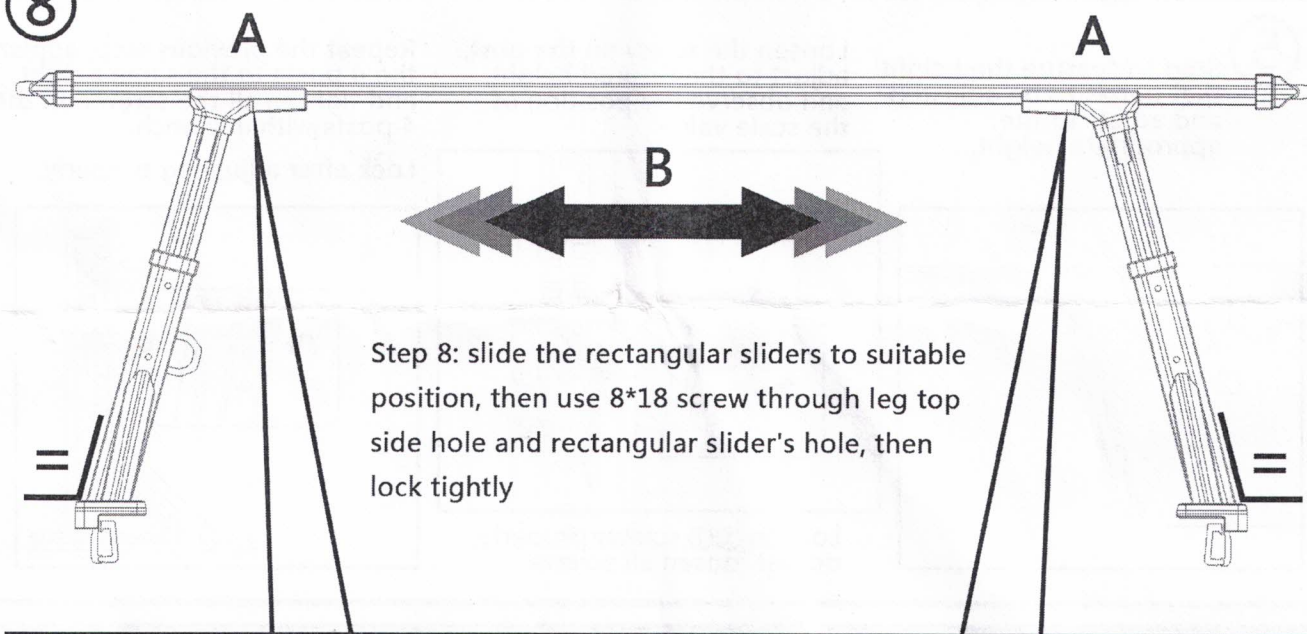

Step 8: slide the rectangular sliders to suitable position, then use 8*18 screw through leg top side hole and rectangular slider's hole, then lock tightly

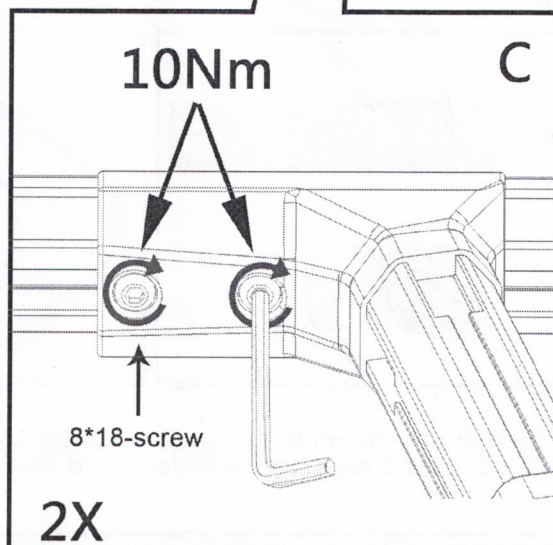
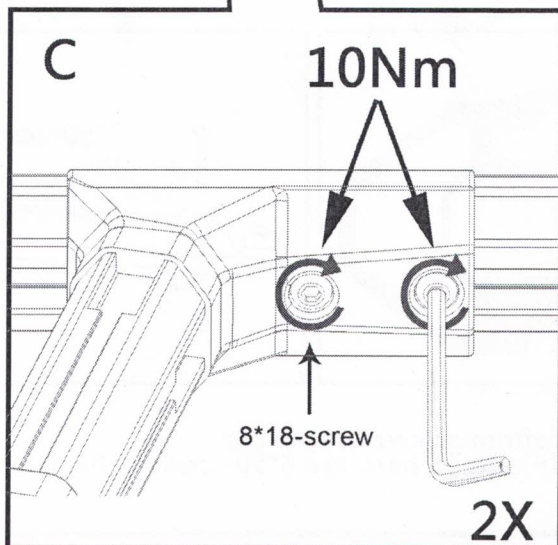

9

Step 9: Check if the front system and rear system are right. Retighten hardware if necessary.

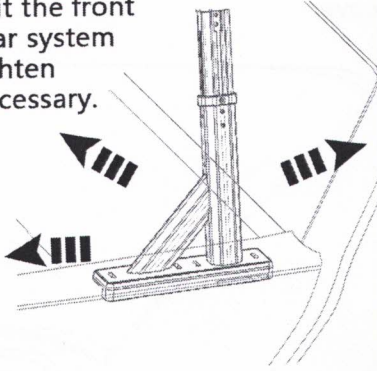

10

Step 10: Adjust the crossbar size according to the distance of the column.

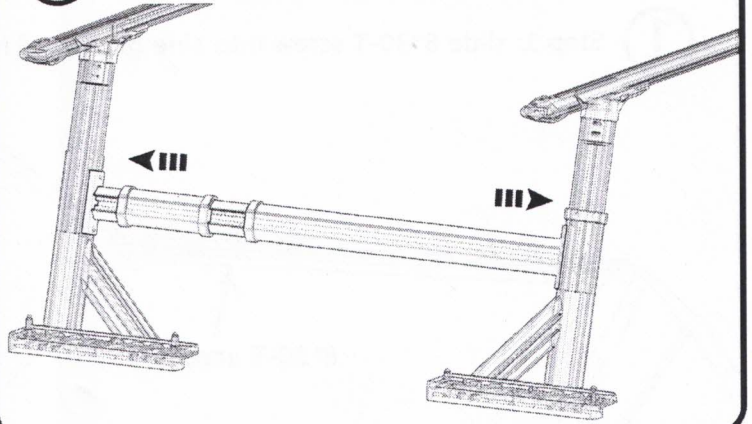

11

Step 11: take side bars, use 8*18 screw to connect side bars and legs

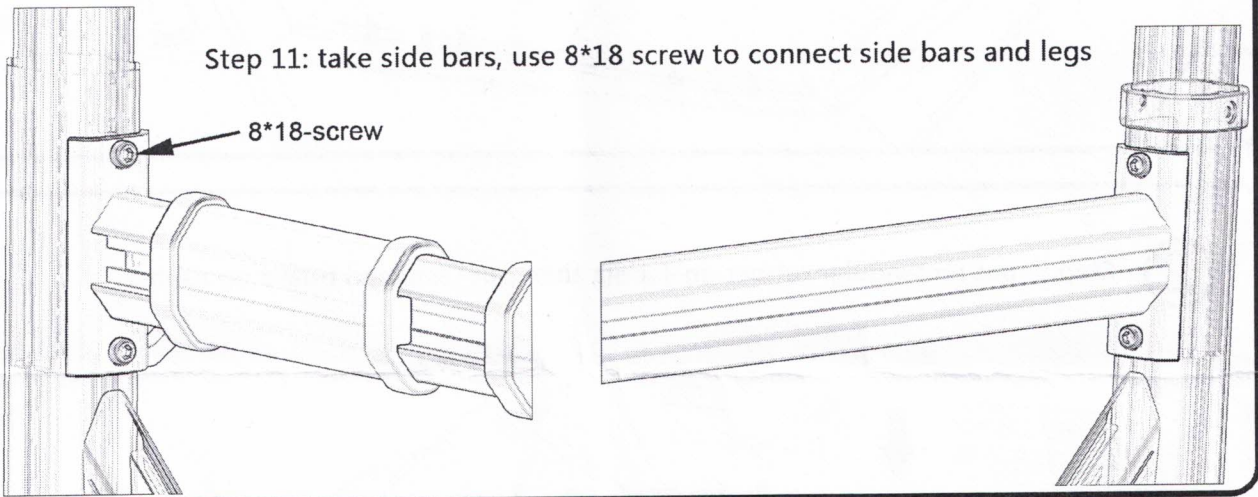

12

Step 12: Installation effect display.

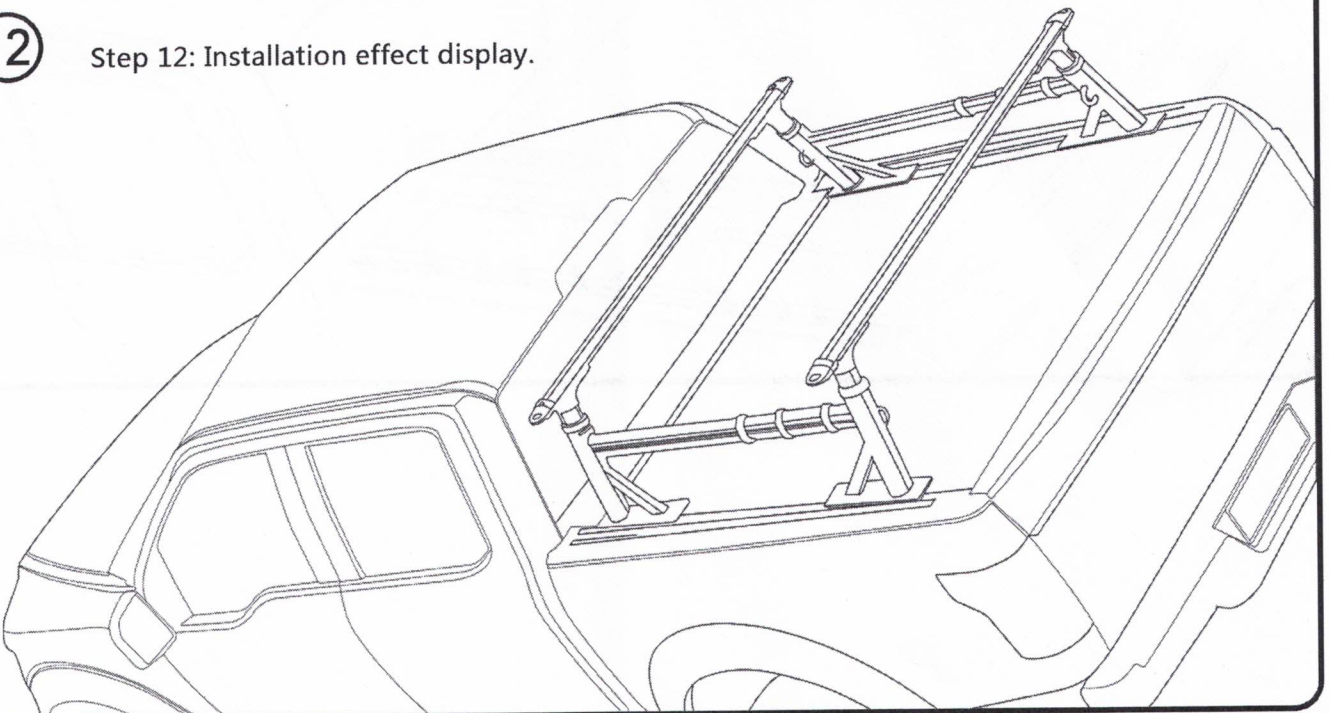

ROLL BAR WITH ROLL COVER

① Step 1: slide 8*30-T screw into side groove of roll cover

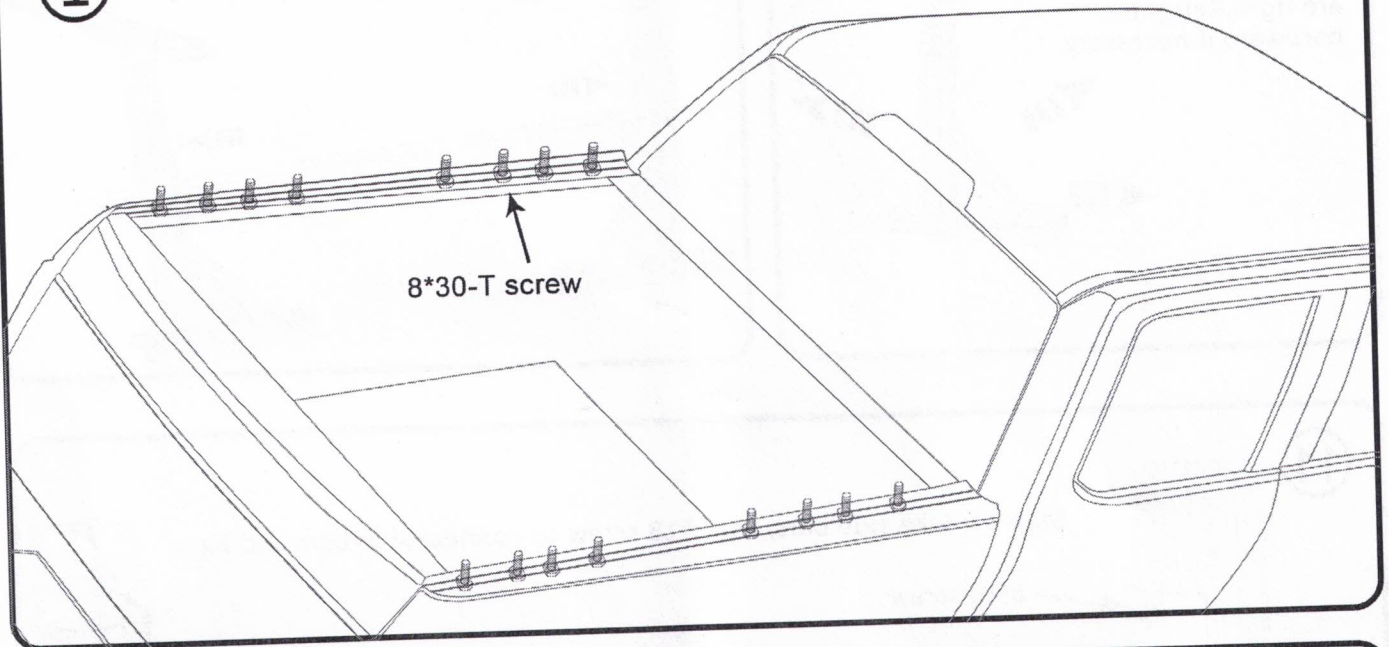

② Step 2: put rectangular rubber on T-bolt, then put L-shaped board on rubber

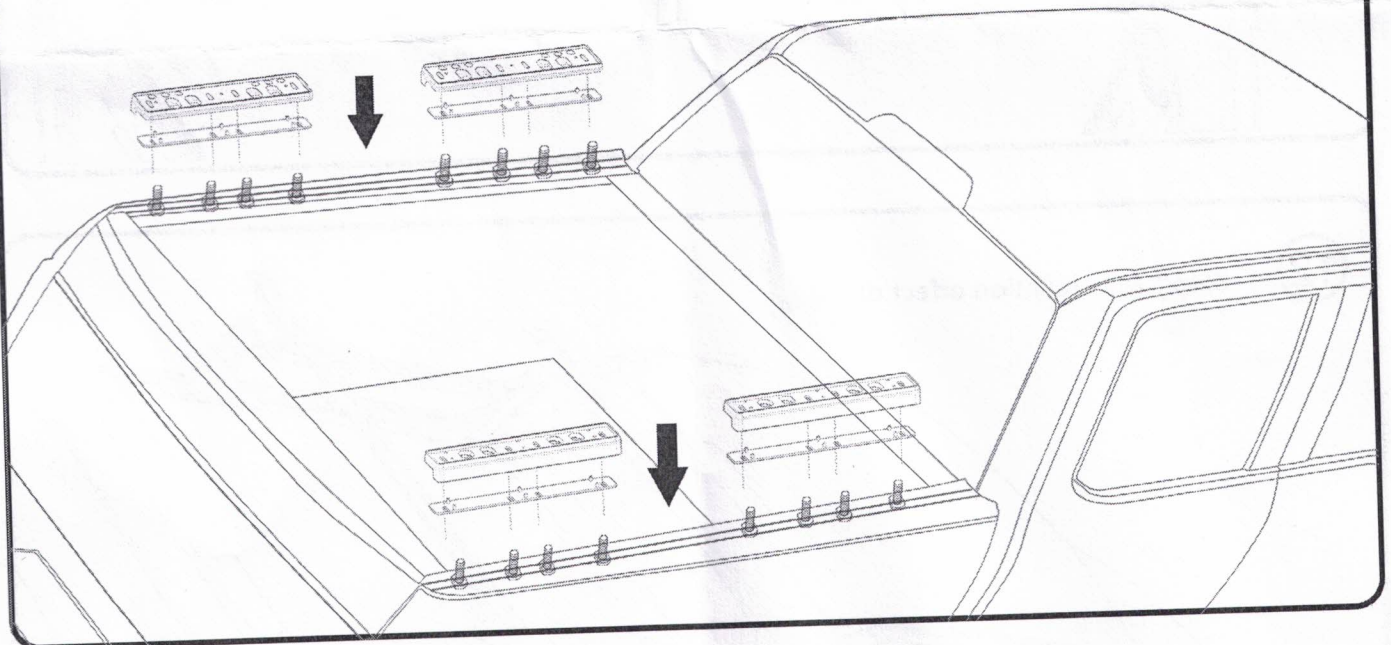

3

Step 4: put 4 legs on 4 L-shaped board, then put pad and nut to lock

Measure the appropriate size, the two sides need to be symmetrical and consistent.

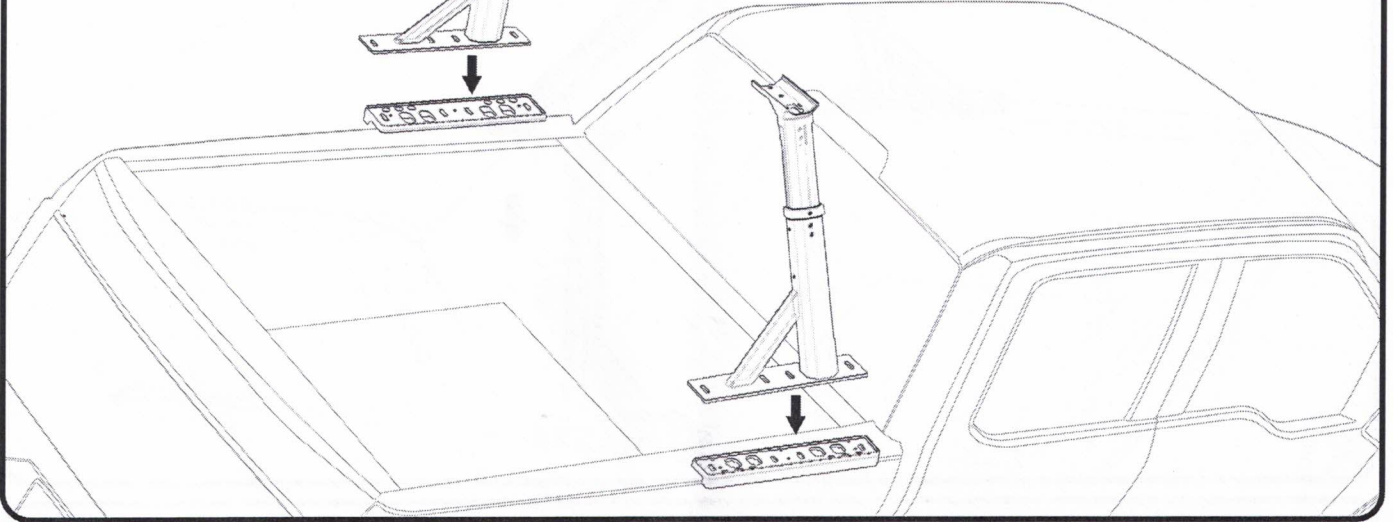

4

Step 5: Measure the height that needs to be adjusted and adjust to the appropriate height.

Loosen the screw on the post, adjust to the desired height, and observe the position of the scale value.

Repeat the previous step, adjust the 4 posts to the same height, and tighten all the screws on the 4 posts with a wrench.

Lock after adjusting properly.

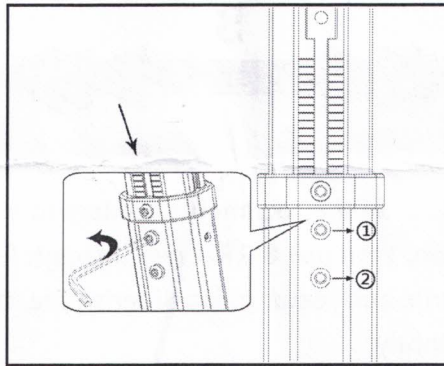
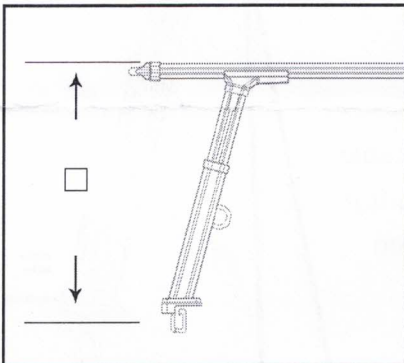

Loosen ①② screws properly, do not loosen all screws.

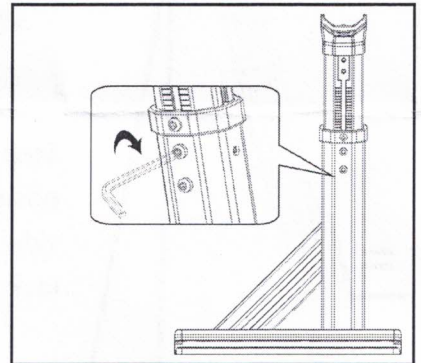

5

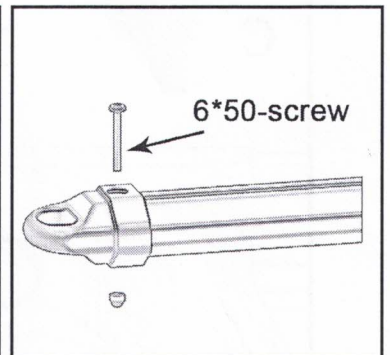
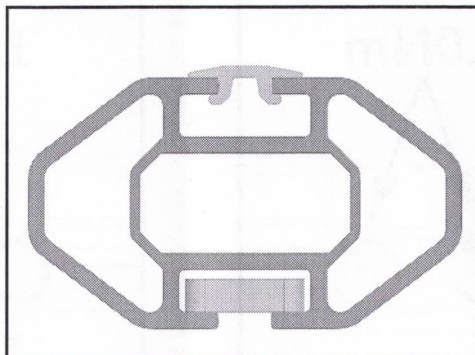
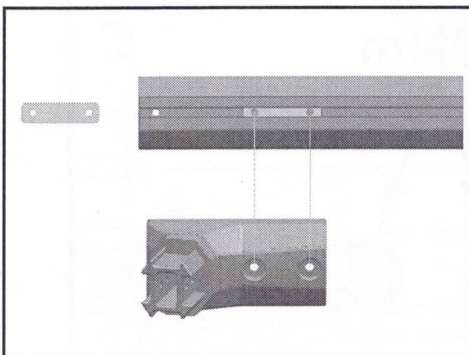

Step 6: put the rectangular slider slides into the bottom groove of roof bar (1 bar puts 2 rectangular sliders) and then put side caps on bars, use 6*50-screw to fix

⑥

Step 7: put roof bars on 4 legs

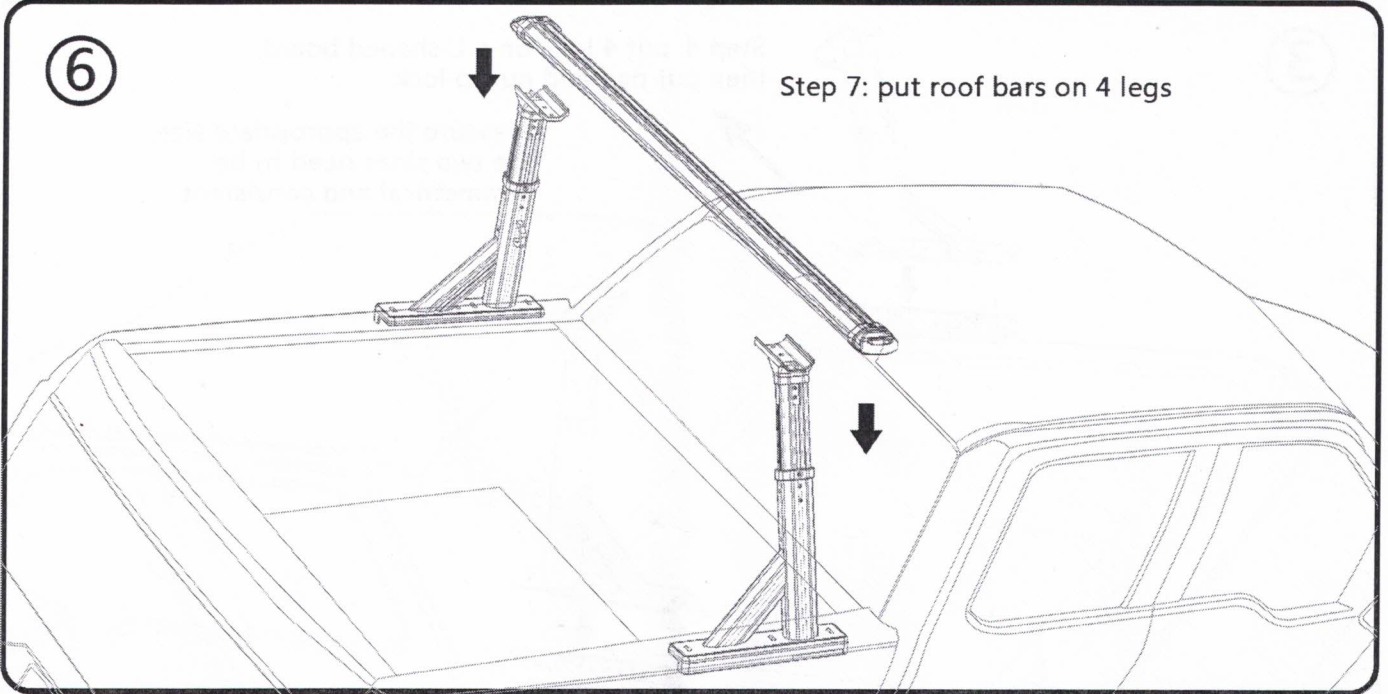

⑦

A

A

B

Step 8: slide the rectangular sliders to suitable position, then use 8*18 screw through leg top side hole and rectangular slider's hole, then lock tightly

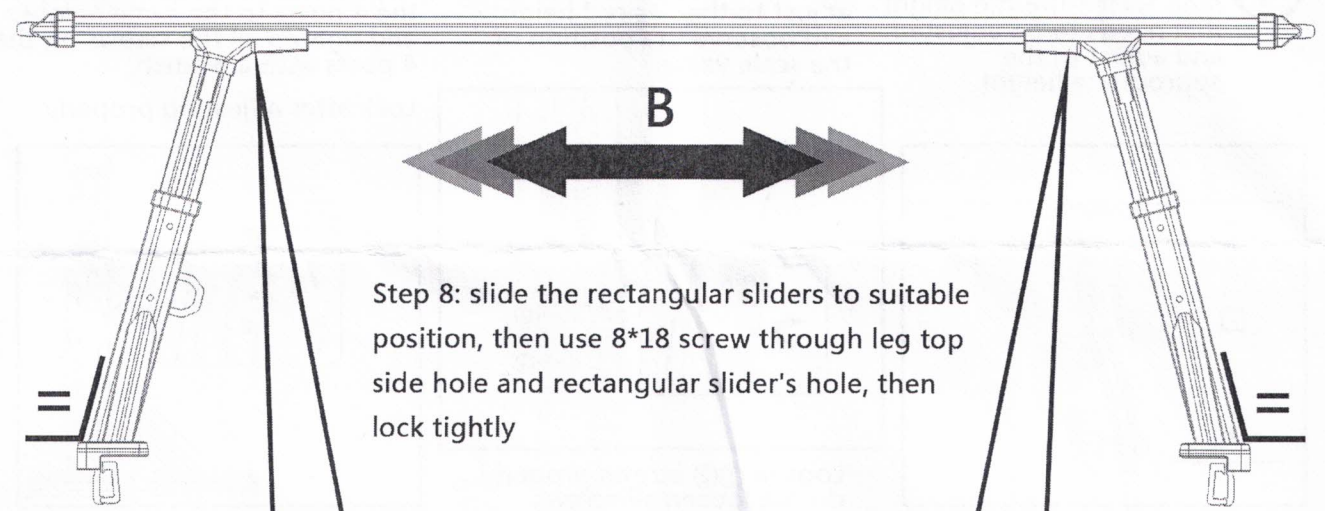

C

10Nm

8*18-screw

2X

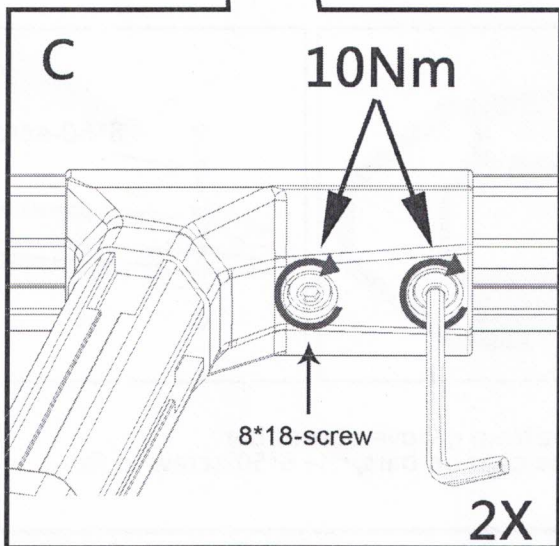

10Nm

8*18-screw

2X

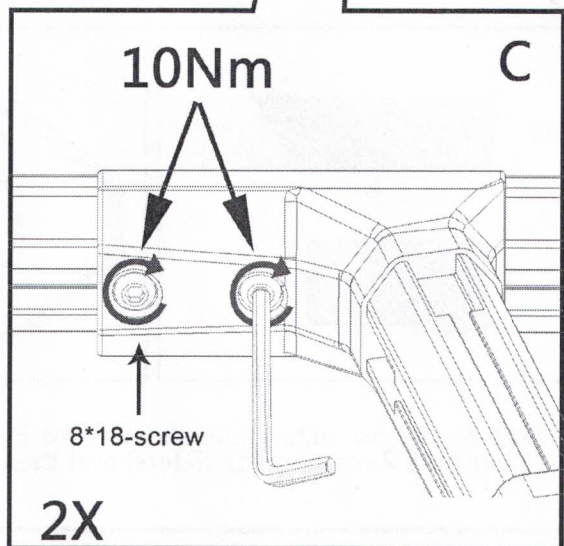

8

Step 9: Check if the front system and rear system are right. Retighten hardware if necessary.

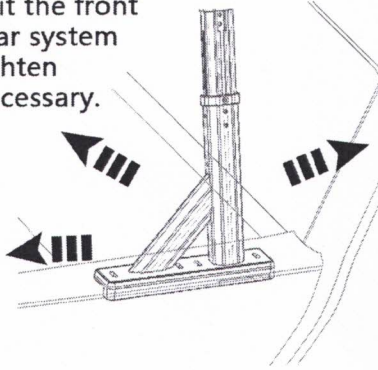

9

Step 10: Adjust the crossbar size according to the distance of the column.

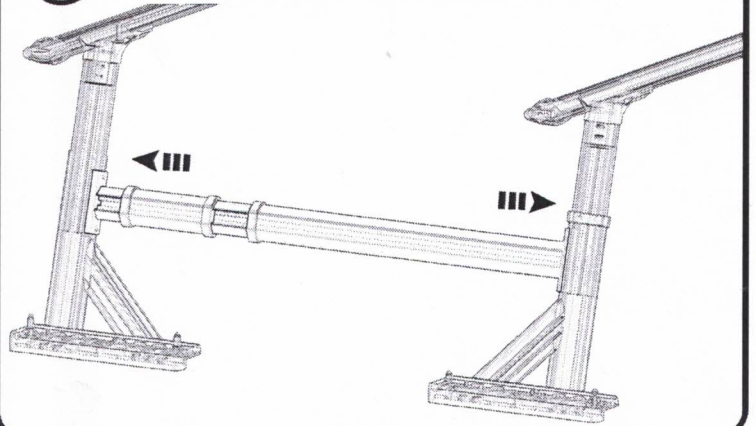

10

Step 11: take side bars, use 8*18 screw to connect side bars and legs

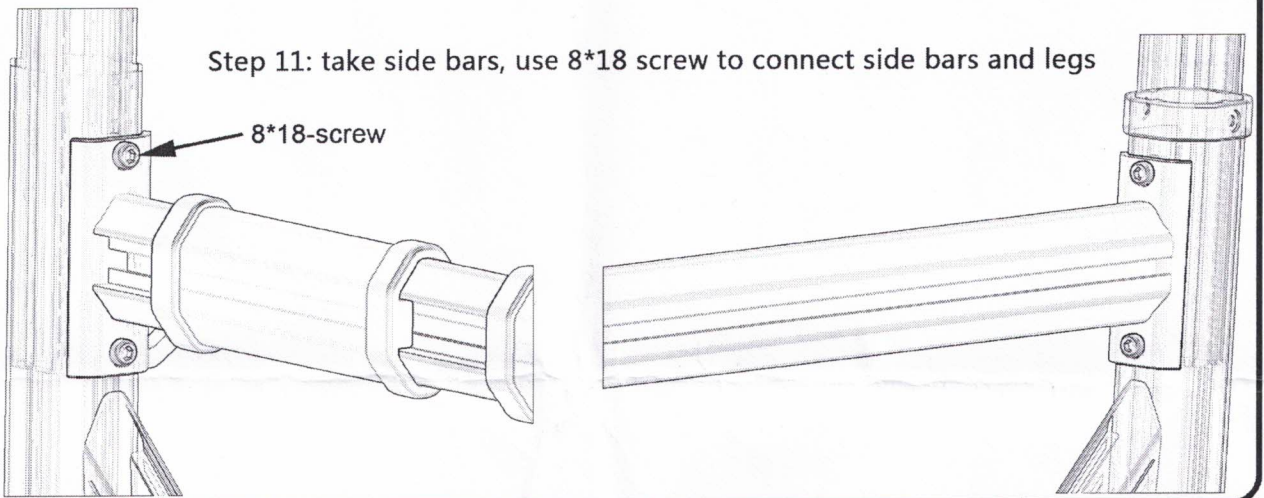

11

Step 12: Installation effect display.

